

# INSTALLATION AND OPERATING MANUAL FOR DAB 4" SUBMERSIBLE PUMPS

**S4A – S4B – S4C – S4D – S4E – S4F**

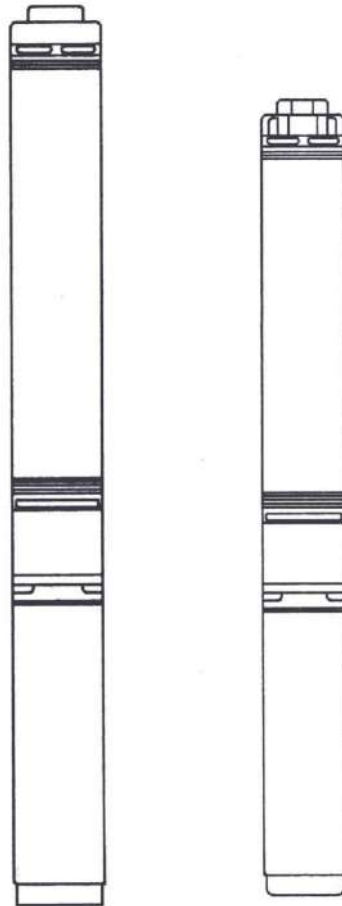

# DAB 4" SUBMERSIBLE PUMP INSTALLATION AND OPERATING INSTRUCTIONS

These instructions supply the necessary information for the installation and operation of 4" submersible pumps, and should be thoroughly read and understood before installation is attempted.

## GUARANTEE

The following Guarantee conditions shall apply to borehole submersible pump installation. White International shall not be held responsible for damage caused by improper installation, use of cable and control boxes, level controls or magnetic starters which are not approved by White International, negligent or careless handling, lightning, improper voltage supply, corrosion due to impure water, wear caused by sand, gravel or other abrasives in the water being pumped.

## IMPORTANT PRECAUTIONS

1. Damage to pump or motor caused by abrasive or corrosive water is not covered by the Guarantee; however, to guard against installing a pump in aggressive water, it is suggested that an analysis of the bore water be submitted to the Department of Agriculture prior to installation to ensure pump suitability.
2. The bore should be clean before installation. The submersible pump must not be used to bail a new bore. Guarantee does not cover failure or wear due to abrasives in the water.
3. Be sure voltage and frequency as shown on the nameplate of the control box and motor are the same as the voltage and frequency on the line to which the motor is to be connected. Minimum voltage at the motor must be 240 volts for single phase and 415 volts for three phase.
4. Do not allow pump to run single phase unless it is properly connected to the correct control box.
5. Do not allow pumps to run dry, against a closed discharge or full open discharge. Refer to table showing minimum and maximum flow conditions.
6. In addition to the check valve built into the pump, it may be necessary to install an additional check valve. This is mandatory for heads greater than 80 metres, or on pressure systems. This will reduce water hammer shocks to the pump.
7. Know the total depth of the bore and ensure that the pump does not rest on the bottom or in sand. Ensure 2 metres (6 feet) clear below the pump to the bottom of the bore.
8. Know the pumping level of the bore and ensure that the pump remains submerged at all times. Use of level controller is recommended. If probe type is used, the probe should be located to switch the pump off when the bore water level drops within 1 metre of the pump suction. Alternatively a probeless control such as TESLA GUARDIAN can be used.
9. A Flow Inducer Sleeve or shroud which ensures that the water is drawn into the pump from below the motor is required when the pump is in open water (i.e. water tank, river or dam), is in a rock well, below casing or set in screens, or well diameter is too large.
10. Do not install borehole submersibles in a crooked bore without gauging first. Lower a gauge which is the same diameter and length as the pump to be used into the bore. If the gauge does not bind, it is safe to install the pump.
11. Never support the weight of the pump by the drop (power) cable or by the safety rope. Refer instructions in section PUMP DROP PIPE.

# TYPICAL SUBMERSIBLE INSTALLATION

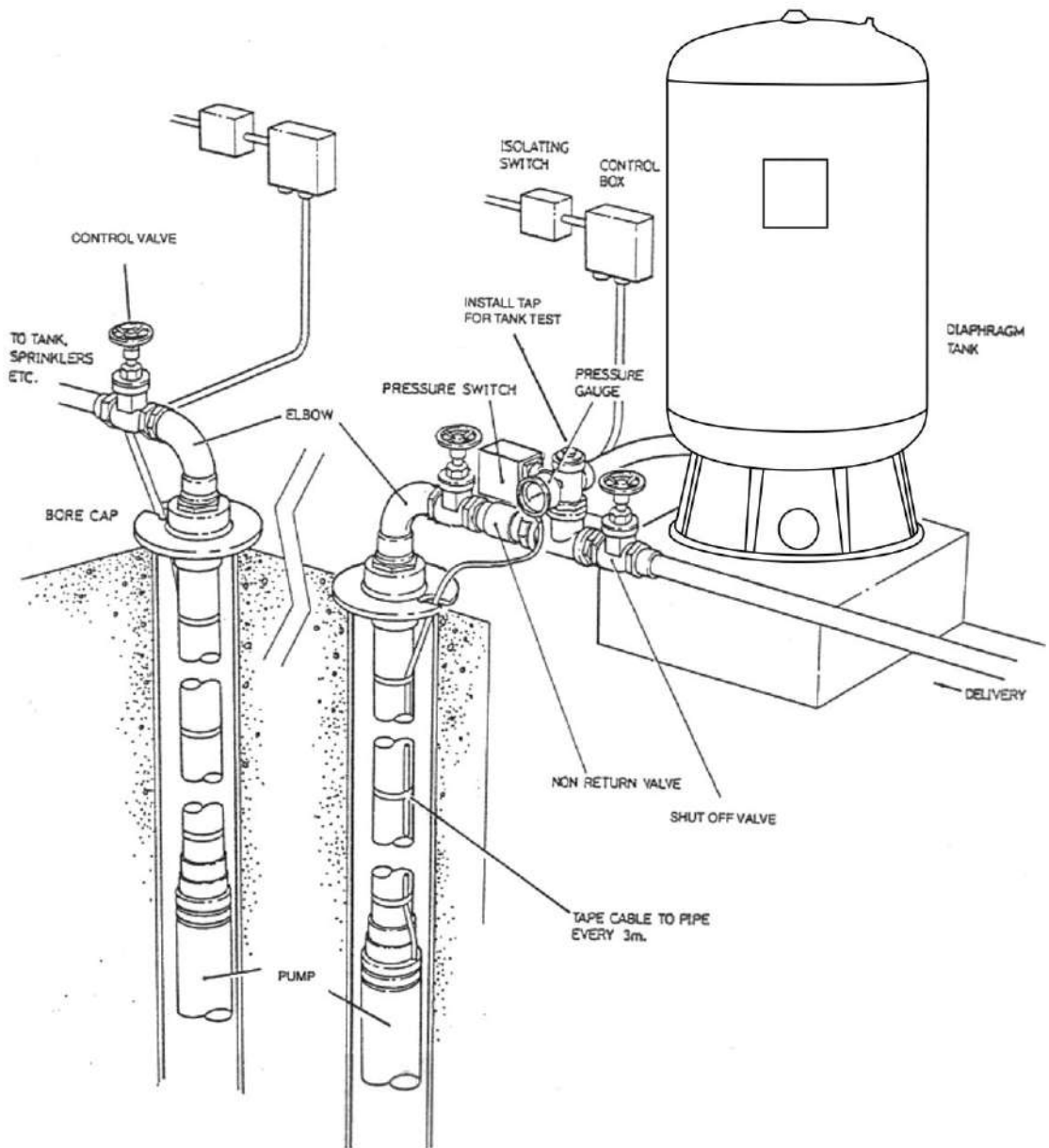

Pump connected for manual operation

Submersible water pressure system incorporating 100 litre pressure tank

## DEPTH OF INSTALLATION

Make sure that the unit is at least one metre above any gravel layer and one metre below the minimum drawdown level. If during the initial operation, the pump lowers the well water level until suction is discontinued, then lower the pump where feasible, or install a protection device, or reduce the flow rate of the pump to prevent over-pumping.

## PUMP DROP PIPE (Pipe Down The Bore)

Polythene drop pipe may be used, provided the pressures and depths indicated in the tables below are not exceeded.

PN RATING	MAX PUMP HEAD (M) BY CURVE	MAX KPA AT TOP OF BORE	MAX PSI AT TOP OF BORE	MAX DEPTH (M)	MAX DEPTH (FT)
6.3	63	0	0	63	207
6.3	63	138	20	49	161
6.3	63	276	40	35	114
6.3	63	414	60	21	68
6.3	63	552	80	7	22
8	80	0	0	80	262
8	80	138	20	66	216
8	80	276	40	52	170
8	80	414	60	38	124
8	80	552	80	24	78
8	80	689	100	10	32
10	100	0	0	100	328
10	100	138	20	86	282
10	100	276	40	72	236
10	100	414	60	58	190
10	100	552	80	44	144
10	100	689	100	30	97
10	100	827	120	16	51
10	100	965	140	2	5
12.5	125	0	0	125	410
12.5	125	138	20	111	364
12.5	125	276	40	97	318
12.5	125	414	60	83	272
12.5	125	552	80	69	226
12.5	125	689	100	55	179
12.5	125	827	120	41	133
12.5	125	965	140	27	87
12.5	125	1103	160	13	41
12.5	125	1172	170	5	18
16	160	0	0	160	525
16	160	138	20	146	479
16	160	276	40	132	433
16	160	414	60	118	387
16	160	552	80	104	340
16	160	689	100	90	294
16	160	827	120	76	248
16	160	965	140	62	202
16	160	1103	160	48	156
16	160	1172	170	40	133
16	160	1241	180	33	110
16	160	1379	200	19	64
16	160	1517	220	5	17

PN RATING	MAX PUMP HEAD (M) BY CURVE	MAX KPA AT TOP OF BORE	MAX PSI AT TOP OF BORE	MAX DEPTH (M)	MAX DEPTH (FT)
20	200	0	0	200	656
20	200	138	20	186	610
20	200	276	40	172	564
20	200	414	60	158	518
20	200	552	80	144	472
20	200	689	100	130	426
20	200	827	120	116	379
20	200	965	140	102	333
20	200	1103	160	88	287
20	200	1172	170	80	264
20	200	1241	180	73	241
20	200	1379	200	59	195
20	200	1517	220	45	149
20	200	1655	240	31	103
20	200	1793	260	17	56
20	200	1931	280	3	10

Polythene drop pipe can be selected by reference to the pump curve and its suitability can be checked on site by checking the maximum pressure read at the top of the bore reference to the maximum depth allowed.

An unstrained safety rope must be connected to all pumps suspended on polythene pipe. This line should be fastened to the lifting hook of the pump. The other end should be fastened at the top of the bore casing or bore cap. The safety rope should be affixed at three metre intervals by a suitable underwater tape with the rope having some slackness between each interval to compensate for the expansion of the polythene pipe when under load.

Care should be exercised to ensure that the polythene pipe is securely fastened to reliable fittings.

If galvanized steel drop pipe is used, it is best installed in three meter lengths to enable easy handling and all threads should be treated against corrosion.

It may be necessary, as a safety precaution to install a non-return valve at the top of the bore. This is in addition to the non-return valve fitted in the pump. This will assure a break down of the water hammer and consequently a reduction of shocks on the hydraulic components (which occurs in any pump system) immediately after each shutdown.

This non-return valve is mandatory where the pump heads (pressure at the top of the bore plus pump depth) exceed 80 m (785 kPa or 262 ft) or where the pump is part of an automatic pressure system.

## WIRING

Wiring should conform to the requirements of local and national electrical codes. If in any doubt, contact your Electricity Supply Authority.

### CAUTION

The use of smaller cable than specified below may cause premature motor failure and will void the warranty. Larger sized cables may be used.

The use of old drop cable or white flat is not recommended. Use water-proof cable only, i.e, Aquaflex AQM rated for immersion to 100 m (500m immersion rated also available) obtainable from White International.

The tables on the next page indicate the correct size electrical drop cable and maximum lengths to be used.

## SINGLE PHASE 240 VOLT CABLE SELECTION

<b>TESLA 240V MOTOR PSC kW (HP) Metric Cable</b>		<b>0.37 (0.5)</b>	<b>0.55 (0.75)</b>	<b>0.75 (1.0)</b>	<b>1.1 (1.5)</b>	<b>1.5 (2.0)</b>	<b>2.2 (3.0)</b>
Stranding	Area mm <sup>2</sup>	metres	metres	metres	metres	metres	metres
7/0.50	1.5	94	67	49	36	29	19
7/0.67	2.5	174	123	91	67	53	36
7/0.85	4.0	279	197	146	106	85	58
7/1.04	6.0	417	296	218	159	126	87
7/1.35	10	701	496	366	268	213	147
7/1.70	16	1117	791	585	426	339	235

## THREE PHASE 415 VOLT CABLE SELECTION

<b>TESLA 415V MOTOR kW (HP) Metric Cable</b>		<b>0.37 (0.5)</b>	<b>0.55 (0.75)</b>	<b>0.75 (1.0)</b>	<b>1.1 (1.5)</b>	<b>1.5 (2.0)</b>	<b>2.2 (3.0)</b>	<b>3.0 (4.0)</b>	<b>4.0 (5.5)</b>	<b>5.5 (7.5)</b>	<b>7.5 (10.5)</b>
Stranding	Area mm <sup>2</sup>	metres	metres	metres	metres	metres	metres	metres	metres	metres	metres
7/0.50	1.5	267	240	185	133	104	77	55	46	33	27
7/0.67	2.5	491	442	340	245	192	142	101	84	61	49
7/0.85	4.0	789	710	546	395	308	229	161	135	98	79
7/1.04	6.0	1180	1062	817	590	462	342	241	202	147	118
7/1.35	10	1982	1784	1372	991	775	575	405	339	246	198
7/1.70	16	3158	2843	2186	1579	1236	917	646	541	392	315

# MOTOR DATA

TESLA							
240V PSC MOTORS							
kW	HP	AMPS Full Load	AMPS Locked Rotor	OHMS Run Winding Black to Blue/Grey*	OHMS Start Winding Black to Brown*	CAPACITOR uF	O/LOAD A
0.37	0.5	3.4	9.2	8.8	18.8	16	4
0.55	0.75	4.8	15.8	5.6	13.5	20	5
0.75	1.0	6.5	20.8	3.5	6.7	25	7
1.1	1.5	8.9	32.0	2.5	5.4	35	10
1.5	2.0	11.2	41.4	1.9	5.0	40	13
2.2	3.0	16.2	50.2	1.6	3.7	60	20

TESLA				
415V MOTORS				
kW	HP	AMPS Full Load	AMPS Locked Rotor	OHMS Across Any Two Leads
0.37	0.5	1.8	6.8	35.0
0.55	0.75	2.0	8.4	25.6
0.75	1.0	2.6	13.0	17.3
1.1	1.5	3.6	14.8	13.0
1.5	2.0	4.6	19.8	8.9
2.2	3.0	6.2	27.3	6.0
3.0	4.0	8.8	40.5	4.2
4.0	5.5	10.5	58.8	3.3
5.5	7.5	14.5	79.8	2.35
7.5	10.0	18.1	86.9	2.0

\* Resistances taken at motor leads.

## CONNECTION TO THREE PHASE STARTERS

A direct on line starter incorporating thermal overload and fuses must be used with all three phase motors, otherwise warranty will be void. Use of non approved fuses may not protect your motor and void warranty.

## CHECK ROTATION OF BOTH SINGLE AND THREE PHASE MOTORS

Both single and three phase motors connected to a supply for the first time may rotate in either direction. It is therefore necessary to find out if the motor is rotating in the correct direction. Motor shaft rotates anticlockwise viewed from the lead grommet end. Change rotation by reversing wires.

If rotation is to be checked on the surface, proceed as follows:

Pour clean water into discharge by holding the non-return valve open so that the shaft bearings and the impellers become wet.

Turn on the power switch and check the shaft rotation is correct.

**WARNING:** The dry running should not exceed 2 to 3 seconds, otherwise seizing may occur due to inadequate lubrication.

If the unit is installed in the bore, then the correct direction of rotation is the one that will give maximum head (pressure) at the same capacity.

To correct a reversed rotation, change any two leads (except earth) from the three phase supply at the motor starter. Mark the leads so that the wires will in future be reconnected to the correct terminals of the starter. Single phase motors wired incorrectly can also operate in reverse. Check wiring.

## **EARTHING SINGLE AND THREE PHASE PUMPS**

All Pump motors are equipped with an earth lead which must be connected to the earth of the incoming power supply. Further, control boxes and starters must also be earthed. If Testing or used outside a well, the motor must be connected to the power supply earth lead to prevent a lethal shock hazard.

## **ELECTRICAL CHECK LIST**

It is recommended that where possible, all electrical connections be carried out before delivery to site.

Always check that the motor gland is tight.

Check control boxes, motors and pumps are as ordered and correctly matched.

Check the motor resistances before and after crimping the drop cable to the motor lead, using the charts supplied, and before the water proof heat shrink is applied.

Make sure that the water proof heat shrink is heated sufficiently to cause resin to flow to create a water tight seal.

If possible, it is good to practice run the pump briefly in a container of water (water must be over the suction inlet) to check on operation before installation in the bore.

Drop cable should be affixed at three metre intervals by a suitable underwater tape with the cable having some slackness between each interval to compensate for the expansion of the polythene pipe when under load.

## **DELIVERY PIPING**

Large diameter pipe should be used for long runs to compensate for pressure losses due to friction. Long pipe runs can cause water hammer and damage to pumping systems. Consult your local borehole specialist as additional check valve and water hammer arrestor (pressure tank) may need to be fitted.

## **PUMP SWITCHING**

**By Float Switches, Pressure Switches, Timers etc.**

(See also section headed "Pressure System Installation")

Provided the switching device used has an adequate current rating, it may be connected directly into the supply line to 240 volt motor control boxes. If the current rating of the switch is not adequate, a starter contactor must be wired into the supply, and the switching device connected to the control circuit of the starter contactor.

In the case of three phase motors, all switching devices should be wired to the control circuit of a suitable starter contactor, and on no account should they be used to directly break the supply circuit to the pump.

**NOTE:** Any automatic switching of the pump greater than 20 starts per hour will shorten the motor life and may void warranty.



## INITIAL STARTING

Before connecting the pump outlet pipe from the bore, bend and gate valve should be screwed into the top of the bore cap as a pump valve.

With the gate valve just slightly open, start the pump.

## NEVER START THE PUMP AT FULL FLOW FOR THE FIRST TIME

Immediately the pump has been started, catch some of the discharge water in a large container and allow the solids to settle out. If little or no sand appears, open the gate valve to 1/3 and pump until the water is clean.

For the first 10 to 20 minutes of operation, it is suggested to keep the gate valve only partially open, to maintain a low flow which will prevent turbulence in the well near the pump and possible seizing of the pump due to excessive sand in the water.

If excessive amounts of sand or other solids are being pumped, shut the pump down, and have the bore attended to before restarting the pump.

Submersible pumps are not guaranteed against failure due to pumping sand. Pumping of sand of even very fine small quantities will shorten the effective life of any pump.

## NEVER OPEN THE GATE VALVE ABRUPTLY

as this may raise sand and deposits.

The pump should be run for a period of 30 minutes to check that it does not pump the bore dry. This would be obvious by large fluctuations on the pressure gauge and the ammeter as the pump flow surges. Continuing operation in this manner could cause serious damage to the pump and motor due to shock pressures as the pump alternately takes up and loses the hydraulic load. This effect is generally referred to as "snoring".

If in doubt about the draw down level of the bore, the use of level controller is recommended. If probe type is used, the probe should be located to switch the pump off when the bore water level drops within 1 metre of the pump suction. The use of a high level probe to automatically turn the pump on is not desired, as a rapid cycling of the pump could occur causing severe damage to the unit. Time clock or manual restart is recommended. Alternatively a probeless control such as TESLA GUARDIAN can be used.

## MINIMUM FLOW CONDITIONS

Premature pump failure may result if pumps are continuously run at flow rates less than the following:

MINIMUM FLOW RATE		
MODEL	LPM	GPM
S4A	6	1.3
S4B	10	2.2
S4C	20	4.4
S4D	33	7.3
S4E	66	14.5
S4F	150	33.0

# MAXIMUM FLOW CONDITIONS

Premature pump failure may result if pumps are run for more than a short period at flow rates greater than the following:

MAXIMUM FLOW RATE		
MODEL	LPM	GPM
S4A	25	5.5
S4B	40	8.8
S4C	72	15.8
S4D	100	22.0
S4E	190	41.8
S4F	440	96.8

## PRESSURE SYSTEM INSTALLATION

When a submersible pump is to be used as a pressure system, the following items are required.

A pressure tank of at least 30 litres draw off. A pressure switch, which is available from White International in a kit complete with pressure gauge and 3 way tee piece which allows plumbing to the pressure tank. A non-return valve at the top of the bore in addition to the pump's in-built non-return valve is required for pressure system application. It is recommended to install an additional gate valve (isolating valve) to allow blow down of the pressure tank to facilitate pressure pre-charge checking.

The 2 pole pressure switch supplied with the kit may be used to break the supply to the control box on single phase pumps up to 1.5 hp. A starter contactor must be used in addition to the control box for single phase pumps above 1.5 hp, and all three phase pumps. One pole of the pressure switch supplied should be used to switch the control circuit of the starter contactor.

The pressure tank connected must be large enough to provide the storage capacity and draw off to limit pump starts to 5 per hour. Use more than one tank if necessary. Do not use "air volume control" tanks from old model pressure systems or primitive non-diaphragm type tanks.

**CAUTION:** *If the available pump pressure at the bore head can exceed the pressure tank's maximum working pressure should there be a pressure switch failure, then a pressure relief valve should be fitted in the delivery line to prevent the tank being over pressurised. Use only nominal 30 litre draw off tanks or larger. Do not at any time use smaller tanks. If cut out pressures exceed 5 bar (500 kPa, 73 psi) fit a 12 bar switch. Pressure switches operated outside their design working range can fatigue and cause pump and fittings failures and void warranty.*

# PUMP SERVICE CHART

THE TROUBLE IS?	WHAT TO LOOK FOR
Overload protector trips	Faulty pressure switch Control box in sun or near heat source Wrong control box being used Defective control box Hydraulic overload Water logged pressure tank Low voltage supply to motor Excessive motor starts
No water delivered	Broken pump shaft or coupling Check valve installed backwards Check valve stuck closed Inlet screen clogged Water level too low in well Hole in delivery pipe below top of bore
Low water delivery	Fittings stopping check valve opening fully Pump rotation backwards Water level too low in well Discharge pipe clogged, corroded or ruptured Pump installed too low in well and covered with sand or other solids Inlet screen partial clogged Worn pump Leak in outlet pipe below top of bore Check valve stuck partially closed
Pump doesn't shut off	Pipe ruptured Defective or improperly adjusted pressure switch  Water level too deep for pump. Check selection  Pump is air or gas bound Worn pump Pipe obstruction Pump needs adjusting
Pump starts and stops too often (i.e. more than 5 per hour)	Incorrect pressure switch, see pressure system installation Defective air valve or tank diaphragm Pressure switch differential adjustment failure Pressure tank is too small

## PUMP SERVICE CHART con't.

THE TROUBLE IS?	WHAT TO LOOK FOR
Fuses blow but overload doesn't trip	Supply cable too small Hydraulic overload Fuses too small Fuse receptacle dirty or corroded Power spike Loose connection in fuse box Defective incoming power leads Excessive motor starts per hour Earth wire connected to wrong control box terminal Cable insulation failure Voltage too high or low
Electric shock from water pipe  Note: A motor down to earth or defective cable will not cause a shock.	Defective (grounded) incoming power leads Defective control box Earth wire connected to wrong control box terminal
Pressure gauge oscillates, flow surges (snoring)	Water level too low in the well. (Flow through pump greater than flow into well)
Electrolysis on motor and pump	Insufficient earth / earth leakage Broken earth wire

NOTE: Always install borehole submersibles with ON/OFF switches and approved circuit breaker to protect against motor damage and electrocution.

# SERVICING AND MAINTENANCE INSTRUCTIONS

## S4 SERIES

### DISMANTLING

**REMOVAL OF THE VALVE BODY (117):** Unscrew the four screws (52), which hold the strainer and cable guard. Remove the strainer (42) and cable guard (39). Loosen and remove the nuts and washers that attach the pump to the motor and separate the pump and motor. Using an oil filter wrench grip the liner (69) and secure the wrench in a vice. Use a spanner to unscrew the valve body (117) from the liner (69). N.B. The thread is left hand. Take care to unscrew the components in the correct direction.

**REMOVAL OF THE PUMP LINER (69):** Grip the pump support (3) in a vice taking care not to damage the support. Using an oil filter wrench, unscrew the liner (69) from the pump support (3). N.B. The thread is left hand. Take care to unscrew the components in the correct direction.

**DISMANTLING THE STAGES:** Remove the upper support (57) complete with pilot bush (270), unscrew and remove the nut (18) and the washer (66). Slide off each stage comprising of diffuser (6), impeller (4), wear ring (191) and diffuser body (98). N.B. Some models have one or two intermediate supports (57) complete with pilot bush (271) and shaft sleeve (58). With a texta mark these supports as the intermediate support and note their position with respect to the pump stages. When all stages have been removed, the spacer bush (55) can be slid from the shaft.

### ASSEMBLY OF THE STAGES

Fit the pump shaft (7) onto the motor and ensure that the coupling engages fully. Fit the spacer bush (55) and the support (3) over the shaft. Secure the support with the motor nuts and washers. Fit the first diffuser body (98) on to the support, followed by the first wear ring (191) and the first impeller (4). Ensure that the impeller metal neck ring fits inside the wear ring. Fit the first diffuser with the conical section of the diffuser's internal wear ring facing up. Repeat this for all stages taking care that impellers fit inside wear ring. Some models will require their intermediate supports (57) complete with pilot bush (271) and shaft sleeve (58) to be fitted at the locations that were previously marked. Fit the washer (66) and tighten the nut (18), and fit the upper support (57) complete with pilot bush (270).

**FITTING OF THE PUMP LINER (69):** Grip the pump support (3) in a vice taking care not to damage the support. Using an oil filter wrench, screw the liner (69) onto the pump support (3). N.B. The thread is left hand. Take care to tighten the components in the correct direction.

**FITTING OF THE VALVE BODY (117):** Using an oil filter wrench, grip the liner (69) and secure the wrench in a vice. Use a spanner to screw the valve body (117) into the liner (69). N.B. The thread is left hand. Take care to tighten the components in the correct direction. Fit the strainer (42) and cable guard (39) using the four screws (52).



# S4A-S4B-S4C-S4D- S4E-S4F

